

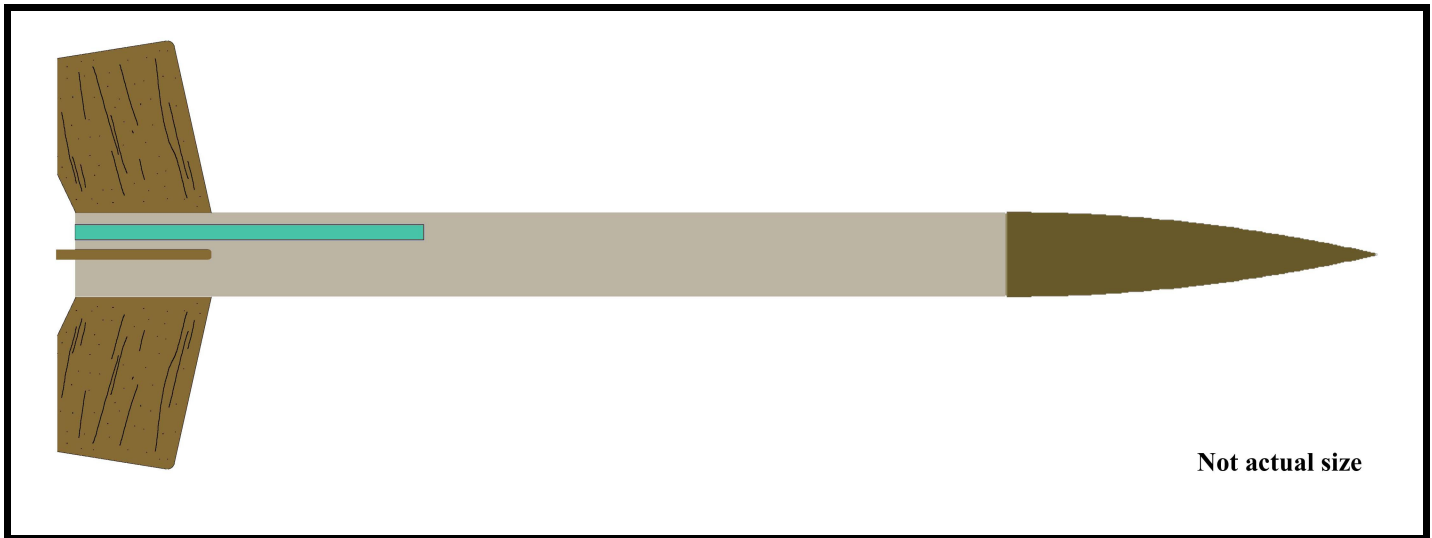

# Pook 19

Created by C. P. McGraw



Length	8.525"
Diameter	0.543"
Fin Span	2.763"
Weight	0.30 oz

### Parts List

- Nose Cone.....BC-517
- Body Tube.....ST-560
- Thrust Block.....TB-5
- Launch Lug.....LL-18
- Fins.....1/16" x 3" x 4"
- Screw Eye..... 1"
- Elastic Chord.....SC-18
- Kevlar Thread.....SCK-24
- Snap Link..... (1) #10

### Additional Items Required

Small bottle of yellow carpenter's glue; sharp hobby knife; 0.05mm pencil; steel ruler; sheets of 220-, 400-, and 600-grit sanding papers; lightweight filler compound; tack rag; sprayable primers, paints, and Acrylic gloss clear coat; small, soft-bristle hobby brushes; various clamps and weights; one expended motor casing.

It is also recommended that you have a personal copy of **The Model Rocketry Handbook, Seventh Edition**, by G. Harry Stine and Bill Stine. Read and understand the sections on Construction, Recovery, and Safety.

## Punk 13

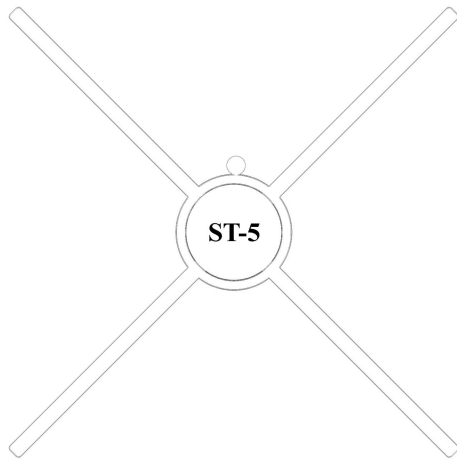

**Fin Alignment Guide**

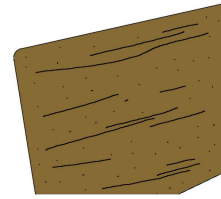

**Fin Pattern**  
Make 4

### *Pattern Sheet*

#### **General Notes:**

All fins are to be cut from 1/16" sheet balsa.

Make multiple copies of the Fin Alignment Guide on some stiff cardstock, and trim away the area inside the lines. You can use these patterns for holding the fins in perfect alignment while the glue dries by slipping the guides over the tube.

We recommend you should read the Construction chapter of The Model Rocketry Handbook for a thorough discussion of the Double-Glue technique for attaching fins and launch lugs to the body tube. Read the chapter on Recovery for a discussion of the "Break-Apart" method used in this model.

## "V" Notch

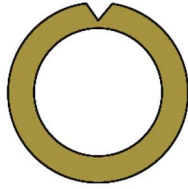

Figure 1

- **Step 1** Using a sharp hobby knife, cut a "V" notch in the outside diameter of the TB-5 thrust block, as shown in Figure 1. Be careful not to slice completely through the ring (or your finger...).
- **Step 2** Tie a slip knot around the TB-5 using the Kevlar thread. Pull the knot tight with the thread aligned in the notch, and the knot itself against one of the faces of the ring.

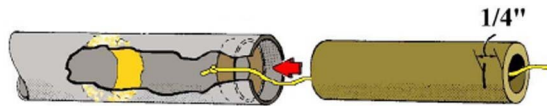

Figure 2

- **Step 3** Mark an expended 13mm motor casing at 1/4" from one end. Apply a generous bead of glue, about 1/4" wide, to the inside of the body tube about 1 1/4" from the bottom end of the tube. As shown in Figure 2, with the knot to the front side of the ring, pull the Kevlar thread down through the center of the casing. Use the casing as a depth gage and push the TB-5 ring inside the body tube, up through the glue, until the mark on the casing is even with the edge of the tube. Remove the casing from the tube, but do not push the Kevlar thread back into the tube at this time. Allow this to completely dry.
- **Step 4** Give the body tube a gentle sanding over the entire surface with 220-grit paper to remove the shine. Gently sand the nose cone with more 220-grit paper to remove the fuzziness and to restore the shape of the cone from any swelling that typically occurs with turned balsa.
- **Step 5** Using the Fin Alignment Guide,

mark the body tube with a pencil for each of the fins and for the launch lug.

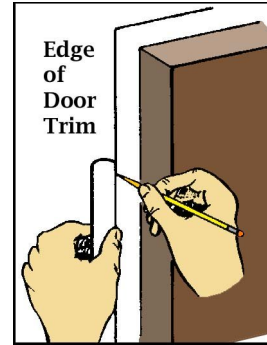

Figure 3

- **Step 6** As shown in Figure 3, using the straight edge of a steel ruler, the trim around a door, or the 12" length of brass angle, draw lines upward from the bottom of the tube for a distance of 1.5" for the fins, and 2.25" for the launch lug.

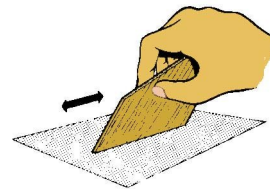

Figure 4

- **Step 7** Cut out all of the fins from 1/16" thick sheet stock. Use 400-grit paper to sand the flat surfaces of all the pieces, and to round over all of the **outer** edges. Do not round over the **root** edges of the fins. As shown in Figure 4, square up the root edges so that the glue surface is as flat as possible with respect to the body tube.

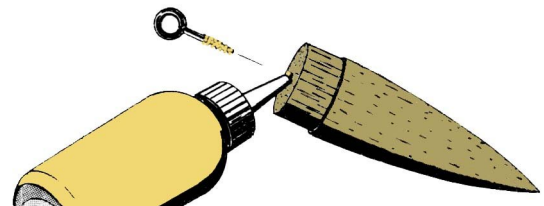
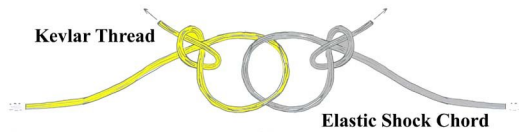

Figure 5

- **Step 8** Use the screw eye to cut threads into the base of the nose cone, then carefully reverse the screw eye out of the hole. As shown in Figure 5, apply glue to the threads of the screw eye, and force glue into the hole.

Re-insert the screw eye until it bottoms out. Do not wipe away the glue that squeezes out. Let the glue dry with the nose cone pointed downward.



*Figure 6*

- **Step 9** Pull the Kevlar thread back through the tube and out the top end. As shown in Figure 6, tie a slip knot in the free end of the thread. Run one end of the elastic shock chord through the loop and tie a slip knot in the elastic. Pull these knots tight against each other, and coat the knot with a layer of thinned yellow glue to lock the knot. Allow to dry, then attach the other snap link to the free end of the elastic chord.

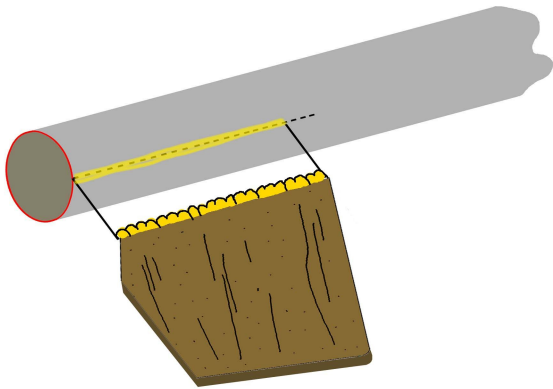
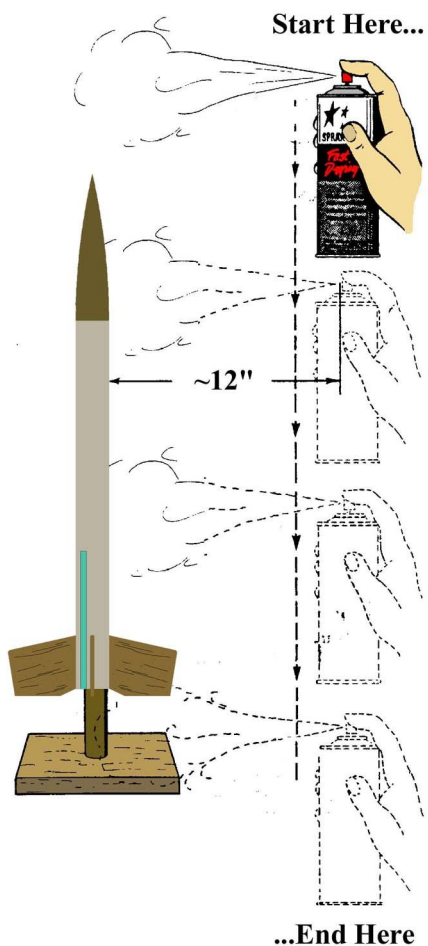

*Figure 7*

- **Step 10** Attach the fins to the body tube, with the bottom of the root edge touching the bottom of the tube, as shown in Figure 7. Use cardboard cutouts of the alignment guide to ensure the fins are properly aligned to the tube. Attach the launch lug in the same manner on the lug alignment line. Allow these glue joints to dry completely.
- **Step 11** After all of the glue on the fins and the launch lug has cured, apply a bead of full-strength glue along these joints and use a soft hobby brush, moistened, to smooth out the glue into a fillet. This will add strength to the joints. Allow these fillets time to dry

before handling the model further.

- **Step 12** Fill the grain of all bare wood surfaces (fins and nose cone) using a lightweight compound. We currently recommend Elmer's **Fill-N-Finish**, thinned to a pea-soup consistency, and brushed into the grain of the balsa. Allow to dry at least a day before sanding with 220- and 400-grit paper. Repeat this step as often as needed to completely fill any surface imperfections.
- **Step 13** Attach the snap link of the shock chord to the screw eye in the nose cone, and then push all of the chord into the body tube. Insert the nose cone into the tube and check for proper fit. The shoulder should fit with some resistance, but not too tightly, or you will suffer recovery failure in flight. The cone should not be loose, either. You should be able to turn the model pointing cone-down without the cone falling out on its own, but it should come out with a light puff of air through the tube from below.
- **Step 14** The illustration in Figure 8 shows the correct way to spray your model, regardless of the equipment used. Always spray the model from top- to-bottom, never from side-to-side, or bottom-to-top. Use a length of 1/2" hardwood dowel as a cheap holding spike. Maintain a distance of about 12" between the tip of the spray and the model. This step applies to primers, paints, and final gloss coats.
- **Step 15** Apply at least two coats of primer to the model before sanding it, allowing time for each coat to dry completely. Our current preference is **Rust-O-Leum** Clean Metal Primer, White. Sand carefully with 220-grit paper to remove the excess primer, then tack-rag to remove the dust. Re-prime and sand as many times as needed to eliminate all visible surface imperfections (such as the spiral wrap in the tube). When you reach a point where you are satisfied with the surface, give the model a final prime and sand with 400- and 600-grit paper to achieve a glass-smooth surface. Tack-rag the model before proceeding.



*Figure 8*

- **Step 16** We recommend spraying the nose cone as a separate item from the body, using a scrap piece of ST-5 as a holding tool. The body should be gloss white, while the nose cone should be bright gloss red, or black. Mask off and spray one of the fins black on both sides.
  
- **Step 17** After the final color trim has been allowed to dry at least a full day, preferably two days, you can apply the Acrylic Gloss Clear coat. We have used clear coat sprays from several manufacturers with good success, but you should always test on something other than your model before making the final commitment. Give the model a complete coverage of the Acrylic, and allow to dry until you cannot smell the solvent anymore.

- **Step 18** We recommend the 1/4A3-2T or 1/2A3-4T as your first-flight motor, while the A3-4T is the only full-power motor we recommend for regular flight. Wrap masking tape around the motor and test-fit into the tube. The fit should be quite snug, more so than the nose cone, and the motor should not easily pop out. Blowing the nose off allows sufficient aerodynamic drag to keep the model from falling too fast, such that no streamer or parachute is needed. Although there is no streamer or parachute on this model, always insert at least one balled sheet of recovery wadding, or about 1" of shredded cellulose fill, into the tube before each flight. This will help protect the shock chord from damage.

**Developed for BARCLONE Rocketry  
by C. P. McGraw**

**Model design copyright © 2005  
by C. P. McGraw**

**Instruction text copyright © 2005**

**All Rights Reserved**

# Model Rocket Safety Code

**Materials:** I will use only lightweight, non-metal parts for the nose cone, body, and fins of my rockets.

**Motors:** I will use only certified, commercially-made model rocket motors, and will not tamper with these motors or use them for any purposes except those recommended by the manufacturer.

**Ignition System:** I will launch my rockets with an electrical launch system and electrical motor igniters. My launch system will have a safety interlock in series with the launch switch, and will use a launch switch that returns to the "off" position when released.

**Misfires:** If my rocket does not launch when I press the button of my electrical launch system, I will remove the launcher's safety interlock, or disconnect its battery, and will wait 60 seconds after the last launch attempt before allowing anyone to approach the rocket.

**Launch Safety:** I will use a countdown before launch, and will ensure that everyone is paying attention and is a safe distance of at least 15 feet away when I launch rockets with "D" motors or smaller, and 30 feet when I launch larger rockets. If I am uncertain about the safety or stability of an untested rocket, I will check the stability before flight and will fly it only after warning spectators and clearing them to a safe distance.

**Launcher:** I will launch my rockets from a launch rod, tower, or rail that is pointed to within 30 degrees of the vertical to ensure that the rocket flies nearly straight up, and I will use a blast deflector to prevent the motor's exhaust from hitting the ground. To prevent accidental eye injury, I will place launchers so that the end of the launch rod is above eye level or I will cap the end of the rod when it is not in use.

**Size:** My model rocket will not weigh more than 1,500 grams (53 oz) at liftoff, and will not contain more than 125 grams (4.4 oz) of propellant or 320 N-sec (71.9 lb-sec) of total impulse. If my model weighs more than one pound (453 grams) at liftoff, or has more than four ounces (113 grams) of propellant, I will check and comply with Federal Aviation Administration (FAA) regulations before flying.

**Flight Safety:** I will not launch my rockets at targets, into clouds, or near airplanes, and will not put any flammable or explosive payload into my rockets.

**Launch Site:** I will launch my rockets outdoors, in an open area at least as large as shown below, and in safe weather conditions with winds speeds no greater than 20 MPH. I will ensure that there is no dry grass close to the launch pad, and that the launch site does not present risk of grass fires.

LAUNCH SITE DIMENSIONS		
Total Impulse (nSec)	Motor Size	Minimum Size
0.00 – 1.25	1/4A – 1/2A	50'
1.26 – 2.50	A	100'
2.51 – 5.00	B	200'
5.01 – 10.00	C	400'
10.01 – 20.00	D	500'
20.01 – 160.00	E, F, G	1000'
160.01 – 320.00	2G	1500'

**Recovery System:** I will use a recovery system, such as a streamer or parachute, in my rockets so that they return safely and undamaged and can be flown again, and I will use only flame-resistant or fireproof recovery system wadding in my rockets.

**Recovery Safety:** I will not attempt to recover my rocket from power lines, tall trees, or other dangerous places.

Model Rocket Safety Code  
developed by the  
National Association of Rocketry  
Revised Code November, 2004